

# Original Operating and Assembly Instructions



## Radial Fan

DN; WN; GR; WB-GR; GT; WB-GT; HR; DG; WR; HT; WT; DV; DGN; WGN; HG; WG; WV; FR; FL

Document Article No. 261164

## Introduction

---

These Operating and Assembly Instructions must be read and understood before assembling the machine.

All individuals responsible for assembling the machine must read and apply these Operating and Assembly Instructions.

Conscientious study of and compliance with the regulations and information contained in the Operating and Assembly Instructions and the safety regulations will aid the operator in achieving the highest possible level of effectiveness and efficiency and a high degree of safety for operating staff during production and during maintenance and repair work.

It is the operator's own responsibility to check whether local regulations are complied with.

The manufacturer assumes no liability for injury to individuals or animals, or physical damage or damage to the machine itself caused by unintended use, failure to observe or inadequate observance of the safety criteria contained in these Operating and Assembly Instructions, or by modifications to the machine or the use of unsuitable spare parts.

These Operating and Assembly Instructions contain basic and special usage information that must be complied with during installation, operation, monitoring and maintenance. Read these safety and warning notices carefully before you start installing or commissioning the Dietz-motoren fans. These instructions must be kept handy for use. It must be ensured that everyone working on the fans can consult these instructions at any time. In addition to these Operating and Assembly Instructions, operating instructions must be provided in compliance with health and safety legislation and the locally applicable ordinance on the use of working equipment.

The fan, the Operating and Assembly Instructions themselves and the details on the type plate form part of Dietz-motoren's scope of supply specified in our order confirmation. These Operating and Assembly Instructions do not apply to fans used in areas at risk of explosion. Applying ATEX-related instructions provided in these Operating and Assembly Instructions to standard fans would mean that these fans were being used in an unintended manner. Please use the separate Operating and Assembly Instructions for Dietz-motoren ATEX fans.

The operator is responsible for ensuring that the fan is used as intended. Dietz-motoren will not accept any liability if its devices and components are not used as intended. In particular, this also applies to particular use and operating conditions that have not been expressly agreed with Dietz-motoren. The warranty will immediately become invalid if unauthorised and unapproved conversions are made to the supplied device. Dietz-motoren accepts no liability for damage and malfunctions resulting from failure to comply with the Operating Instructions.

## Contents

<b>1</b>	<b>General Information</b>	<b>2</b>	<b>5</b>	<b>Maintenance and Inspection</b>	<b>23</b>
1.1	Machine Type	2	5.1	Safety Notices	23
1.2	Manufacturer and Service	2	5.2	Spare Parts	23
1.3	Use	3	5.3	Notices	24
1.3.1	Intended Use	4	5.3.1	Cleaning, Servicing and	
1.3.2	Unintended Use	5		Repairs	
1.4	Main Components	6	5.3.2	Fastening Elements	25
1.5	Operation	7			
<b>2</b>	<b>Safety</b>	<b>8</b>			
2.1	Identification of Notices in the Assembly Instructions	9			
2.2	Staff Qualification and Training	10			
2.3	Hazards if Safety Notices are Not Observed	11			
2.4	Safe Working Practices	11			
2.5	Safety Notices for the Operating Staff	12			
2.6	Safety Notices for Maintenance and Servicing	12			
2.7	Unintended Use	12			
2.8	Hazards	14			
2.9	Conduct in Hazardous Situations	15			
2.10	Additional Notices	15			
<b>3</b>	<b>Transport and Installation</b>	<b>16</b>			
3.1	Safety Notices	16			
3.2	Installation Site	17			
3.3	Installation and Mounting	18			
3.4	Disassembly and Transport	19			
<b>4</b>	<b>General Operating Instructions</b>	<b>20</b>			
4.1	Safety Notices	20			
4.2	Operating Instructions	21			
4.3	Connection to the Mains Power Supply	22			
4.4	Checking the Direction of Rotation	22			
4.5	Decommissioning the Radial Fan	22			
4.6	Disposal	22			

## 1.1 Machine type

Radial fan: DN; WN; GR; WB-GR; GT; WB-GT; HR; DG; WR; HT; WT; DV; DGN; WGN; HG; WG; WV; FR; FL

Serial number:

## 1.2 Manufacturer and service



Dietz-motoren GmbH  
Kirchheimer Str.164  
D-73265 Dettingen/Teck  
Germany  
Tel.-Nr.: +49 7021 57 02 - 0  
Fax-Nr.: +49 7021 57 02 - 14  
vertrieb@dietz-motoren.de  
www.dietz-motoren.de

## 1.3 Use

### 1.3.1 Intended use

**WARNING** The incomplete machine (radial fan) is designed for installation in a machine.

For detailed specifications on the type range, please refer to the technical data in Section 1.4.



In particular, the operator must ensure that the fan is only used as intended, is only run when in a fully functional condition and, most importantly, check regularly that the safety equipment is working properly.

Unauthorised conversions or modifications are not permitted.

Dietz-motoren standard fans are not permitted for use with aggressive, toxic or very moist media.

The maximum temperature of the medium flowing through fans that are not used as specified in the ATEX Directive 2014/34/EU must not exceed +80°C.

Fans with a temperature barrier are designed for a medium with a higher temperature. Ask Dietz-motoren about the permitted limit values.

Particulate matter or impurities in the medium flowing through the fan must be filtered out before the medium enters the fan. The maximum ambient temperature must not exceed +40°C and the minimum ambient temperature must not fall below -20°C. The permitted ambient pressure range is between 0.8 and 1.1 bar.

**Special versions for use in applications other than those described above must be requested separately. It is not permitted to convert or modify the fan**

## 1.3 Use

### 1.3.1 Intended use

#### Intended use includes:

- The device is upright with its drive shaft installed horizontally, i.e. the fan/impeller and its support plate is installed vertical to the ground.
- Installation with a vertical shaft and horizontally positioned impeller is only permitted if there is a protective roof over the drive fan cover. Note that, if the device's drive shaft is installed vertically, the bearing life will be reduced and the condition of the bearings must be checked more frequently.
- The ambient temperature is within the permitted limit values of -20°C to +40°C.
- The media flowing through the fan and the surroundings are free of elements that might attack the material, such as acids, lyes, solvents, flash rust, iron oxides or aggressive or abrasive gases or liquids.
- The medium flowing through the fan is free of sticky or condensed-out elements.
- For safety reasons, the fan must not be operated in the far left-hand maximum range of the fan characteristics curve.
- The potential risk of the impeller pumping that sometimes occurs in particular operating statuses, must be avoided.
- The fan must not be operated above the respective volumetric flow limit (refer to the details on the type plate). The fan must not be run in "free blowing" operation.
- The motor must be restricted to the rated current and monitored using a motor protection switch. Values according to motor rating plate.
- The minimum volumetric flow must be at least 30% of the rated volumetric flow.
- Depending on use, Dietz-motoren fans might leak if used with gases. There is no gas-tight seal between the fan's interior and its exterior. If necessary, the operator must put suitable measures such as ventilation for the area surrounding the fan in place. Technically sealed versions of the fan can be provided by special arrangement with the customer. Special designs can be produced on request.
- Connected pipes, hoses, flanges, consoles or other device mounting equipment can influence the vibrations that affect the fan, or that are caused by the device if it breaks down. The fan must not be subjected to vibrations. Install dampers between the connections and also the foot attachments to prevent the transmission of vibrations.

## 1.3 Use

### 1.3.1 Intended use

#### Intended use does not include:

- Special ambient conditions such as an ambient temperature at the place of assembly/use that exceeds +40°C or is less than -20°C, dust deposits, vibrations at the fan's place of assembly/use.
- Operation in the presence of/with flames or hot gases. The fan must not be used as a sealing device or flame trap.
- Do not use abrasive media. It is essential that the user checks, cleans and maintains the fan at regular intervals.
- Transport of foreign bodies. Fans that are specially designed to handle particles or flue gases in the air flowing through them can be provided by special arrangement with the radiation, ultrasound.
- Adiabatic compression and shock waves, lightning, electromagnetic waves, ionising ionisierende Strahlung, Ultraschall.
- Operation with dusts, and with conductive dusts that have a tendency to self-ignite.
- For devices that cannot be run in "free blowing" operation, the volumetric flow must be restricted as stated on the rating plate.
- Installation and operation of the fan in areas at risk of explosion.
- Foreign bodies must not enter the fan through additional attached components such as protective grilles, pipes, hoses, flanges, dampers, etc
- Running the motor in reverse and reverse current braking are not permitted.
- Layers of dust on the surface of the fan and motor are not permitted!
- Dust particles produced from explosive substances that do not require atmospheric oxygen to ignite, and other spontaneously combusting substances, are not permitted.
- Particular uses and operating conditions that can increase the potential risks. This information must be given to Dietz-motoren in advance and agreed upon.

#### Intended use also includes:

- Observing all the instructions in the Operating and Assembly Instructions.
- Complying with inspection and maintenance work.
- Observing the General and Special Safety Notices in these Operating and Assembly Instructions.
- Observing the relevant accident prevention regulations.



**Any other use or use extending beyond this is considered unintended use.**

**The machine operator is responsible for all personal injury and physical damage that results from unintended use.**

#### **WARNING**

**This machine may only be operated in conjunction with a main machine that complies with the regulations set out in the Machinery Directive!**

## 1.3 Use

### 1.3.2 Unintended use

Unintended use that can cause hazards for the machine, the user and third parties, includes:



- Failure to use the radial fan in accordance with the proper use practices (1.3.1), in particular, this applies to:
  - Installing the fan in machines not intended for this purpose.
- Operating the radial fan outside of the permitted area of application.
- Failure to operate the radial fan in accordance with the regulations set out in the Operating and Assembly Instructions, in the areas of:  
safety, installation, operation and use, setup, maintenance and servicing, troubleshooting
  - Operating the radial fan without additional protective fixtures provided by the operator to prevent unintentional interference during operation.
- Operating the radial fan despite obvious faults.
- Repair and maintenance work without first shutting down the radial fan and securing it against unintentional restarting.

**ACHTUNG NO MODIFICATIONS OR CONVERSIONS MAY BE MADE TO THE DESIGN OF THE FAN SUPPLIED WITHOUT THE MANUFACTURER'S PRIOR APPROVAL. ANY NECESSARY TECHNICAL SAFETY PRECAUTIONS ARE EXPRESSLY EXCLUDED FROM THIS.**

## 1.4 Main components

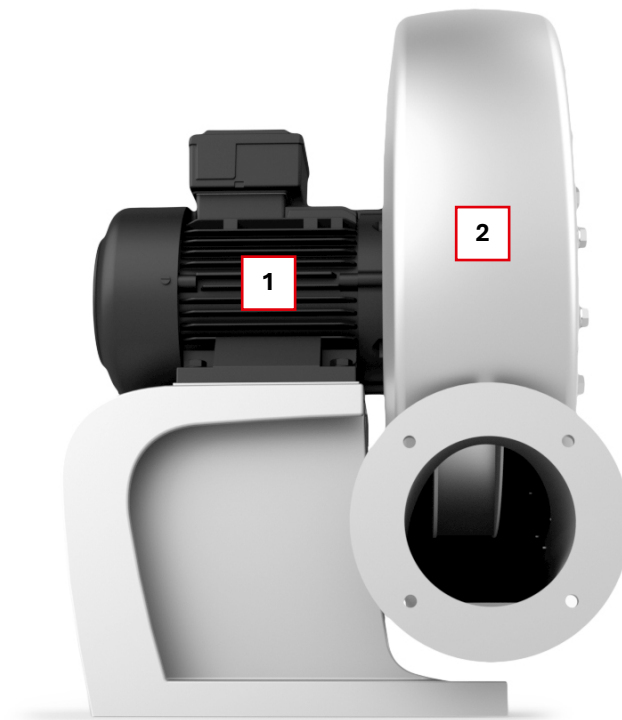

Image: 1.4 Radial fan

---

**No. Component name**

**1 Drive**

**2 Fan housing with impeller**



---

## 1.5 Operation

If the rated current of the drive motor is exceeded during operation, check whether the mains voltage and frequency match the fan data.

See type plate.

The motor in fans that cannot be used across the full characteristics curve might become overloaded if the system resistance is too low (excessive power consumption).

In this case, use the throttle valve on the inlet or discharge side to reduce the volumetric flow rate during first-time use. Alternatively, reduce the fan speed (if a frequency inverter is in use). To prevent this hazard from occurring again, do not undo these settings while the fan is in operation.

The fan must not be subjected to impermissibly high vibration or shock loads.



These Operating and Assembly Instructions contain basic information that must be complied with during installation, operation and maintenance. It is therefore essential that the relevant specialist/operator reads these Operating and Assembly Instructions and that they are available at the radial fan's place of use at all times.

**In addition to the general safety notices listed under this main section entitled "Safety", the special safety notices provided under the other main sections must also be observed.**

### General safety information

The radial fan may only be used and operated properly and as intended by appropriately trained staff. Otherwise, the system may pose risks to staff, individuals present, the machine itself and third parties.

All individuals responsible for operating or maintaining the system must have read and understood the Operating and Assembly Instructions.

Maintenance staff must also observe the manuals or documentation for the components of the machine that the radial fan is installed in and, in particular, ensure that their safety requirements are met.

### Health and safety

Dietz-motoren fans are renowned for a high level of operational safety. Because these fans are very powerful machines, it is imperative that you comply with the safety notices listed in the Operating and Assembly Instructions to avoid injury and physical damage, including to the machine itself.

The Dietz-motoren fan must only be installed, connected, commissioned, serviced and maintained by qualified specialists. The operator must clearly regulate and monitor staff scopes of responsibility and responsibilities.



**The device is operated with high electrical voltage and drives mechanical parts that rotate in a dangerous manner. Ignoring this information might result in physical damage or in severe or even fatal injury.**

Only a trained specialist is permitted to perform the electrical installation work for the fan and components. They must do so in compliance with these Operating and Assembly Instructions and the applicable regulations.



If it can be assumed that safe operation is no longer possible, the device must be taken out of service and locked to prevent it from being operated by mistake.

When work is performed on the machine, it must be locked to prevent it from being switched back on again. The machine or system operator must run their operations in accordance with country-specific regulations and take additional protective measures to prevent risks during operations.

The fans are intended for installation in systems. Objects must be prevented from entering the fans. If piping is not connected to the intake or discharge side, a protective grille must prevent objects from entering the fan or other suitable measures must be taken. These must be at least IP20 rating in accordance with the currently applicable standard.

### Conduct after accidents and disasters

The fan must not be brought back into operation after any type of accident or disaster, e.g. objects colliding with the fan. In these cases, Dietz-motoren must be given access to the fan, or the fan must be returned to Dietz-motoren. The operator must document the causes of the incident and the surrounding circumstances before taking the fan out of operation. This information must be given to Dietz-motoren.

---

### 2.1 Identification of notices in the assembly instructions

#### Intended use includes:

The safety notices set out in these Operating and Assembly Instructions that can cause hazards to individuals if not observed are specifically identified with the general hazard symbol



Safety signs in accordance with ASR 1.3, DIN EN ISO 7010 (incl. Amd 1 – Amd 7) and DIN 4844-2

Safety notices that can cause hazards for the machine and its functions if not observed are indicated by the word

**WARNING** Notices attached directly to the machine must be strictly observed and kept in a fully legible condition.

### 2.2 Staff qualifications and training

Staff for operation, maintenance, inspection and assembly must have the appropriate qualification for this work.

The scope of responsibility, responsibilities and staff monitoring must be precisely regulated by the operator. If a staff member does not have the necessary knowledge, they must receive training and instruction. The manufacturer can carry this out on the operator's behalf if necessary. The operator must also ensure that the staff fully understands the information contained in the Operating and Assembly Instructions.



**Servicing measures may only be carried out by individuals with specifically proven expertise. Depending on the scope and degree of difficulty of the assigned servicing measures, the assigned staff member may need different qualifications.**

#### **Definition: trained staff member**

A trained staff member is an employee who has been informed of the tasks assigned to them and of the possible hazards that could occur in the event of improper conduct. If necessary, this staff member has also received training and instruction on the necessary protective equipment.

#### **WARNING Definition: specialist**

A specialist is an individual who is capable of assessing the work assigned to them and recognising potential hazards due to their professional training, knowledge and experience, as well as their knowledge of the relevant regulations. In addition to (general) training, a specialist must also have received instruction in the particular aspects and specific safety requirements before they are allowed to work on the system. This instruction is usually carried out as part of a training course performed at the machine.

#### **Mandatory qualification**

If a staff member does not have the necessary knowledge, they must receive the appropriate training. The system operator is responsible for checking the operating staff's specialist qualifications and for training them.

---

### 2.3 Hazards if safety notices are not observed

Failure to observe the safety notices may result in hazards for people, the environment and the radial fan. Failure to observe the safety notices may result in the loss of any claims for damages.

In particular, failure to observe the safety notices may result in the following hazards:

- Failure of important radial fan functions
- Failure of required maintenance and servicing methods
- Hazards to individuals due to electrical and mechanical effects

### 2.4 Safe working practices

The safety notices listed in these Operating and Assembly Instructions, existing national accident prevention regulations and any internal work, operating and safety regulations set down by the operator must be observed.

---

### 2.5 Safety notices for the operating staff

- This machine may only be operated by individuals who have received appropriate instruction and who are familiar with the machine's function and can therefore handle it.
- Safety and protective fixtures must not be bypassed, removed without prior authorisation or rendered unusable.

### 2.6 Safety notices for maintenance and servicing

The operator must ensure that all maintenance, inspection and assembly work is carried out by an authorised and qualified specialist who has received sufficient information by studying the Operating and Assembly Instructions in depth.

**In principle, work on the machine must only be carried out when it is stationary and disconnected from any current or voltage, in compliance with the safety regulations.**

**Environmentally sound disposal:**

Dispose of waste produced during maintenance/repair in an environmentally sound manner.

### 2.7 Unintended use

The operational safety of the incomplete machine supplied is only guaranteed if it is used as intended according to Section 1 of these Operating and Assembly Instructions.

### 2.8 Hazards



#### Temperature

During operation, the fan housing temperature rises to the temperature of the medium passing through it, among other things. At temperatures above +50°C, the operator must provide protection so that the fan cannot be touched directly. (Risk of burns!)



#### Faults

If faults or operating statuses that could compromise the safety of the operating staff arise, the machine must be brought to a standstill by immediately disconnecting the air supply. In this case, the intended status must be properly restored.

#### Intake effect

Fans produce a strong suction effect. Objects, clothing and hair might be sucked in at the suction nozzle/cover.

#### Risk of injury!

Do not stand near the intake opening during operation. The optional protective grille on the intake side must only be removed if a sturdy hose, or a pipe connection (at least 1 m long), is connected in its place. Never run the fan with an open intake opening. Risk of injury from impeller!

#### Blow-out effect

If faults or operating statuses that could compromise the safety of the operating staff arise, the machine must be brought to a standstill by immediately disconnecting the air supply. In this case, the intended status must be properly restored.

#### Imbalance/vibrations

When the rotors and impellers in Dietz-motoren fans are delivered, they are balanced to at least balance quality G6.3, in accordance with the currently valid version of ISO 21940-1, or better. On delivery, the maximum vibrations they produce in the motors incorporated are, at least, compliant with the currently valid version of DIN EN IEC 60034-14 vibration quality A, and, for the entire fan unit, the currently valid version of ISO 14694. Both the balance state and the balance quality can deteriorate due to operating conditions, if they are not transported correctly, if they are subjected to impact stress from being put down roughly or if they are stored in unsuitable conditions.

If the vibration values exceed the permitted threshold values defined in the currently valid version of ISO 14694 after commissioning, this will create a considerable danger to operating staff and compromise the machine's safety. During commissioning, the vibration values generated by fans with installed electrical power use below 75 kW that are permanently fixed in place must not exceed 4.5 mm/s.

If they do, the operator must remove the fan from service without delay and send it to the Maintenance department. We recommend you do not wait until the switch-off threshold defined in the currently valid version of ISO 14694 is reached, but instead remove the fan from service as soon as the warning value is reached.

### 2.8 Hazards



#### **UNAUTHORISED ACCESS PROHIBITED**

The user company must ensure that no unauthorised individuals (e.g. visitors) enter the machine's working and hazardous area.



#### **STORAGE PROHIBITED**

If faults or operating statuses that could compromise the safety of the operating staff arise, the machine must be brought to a standstill by immediately disconnecting the air supply. In this case, the intended status must be properly restored.



#### **FIRE, NAKED FLAMES AND SMOKING PROHIBITED**

Fire, naked flames and smoking are prohibited in all areas of the system.



**ACHTUNG**

**Additionally, despite all precautions taken, there may still be non-obvious residual risks.**

**Residual risks can be minimised by observing the safety notices and intended use practices, as well as by observing the Operating and Assembly Instructions as a whole.**

**It is prohibited to operate this machine until it has been ensured that all the health and safety requirements as set out in the EC Machinery Directive have been met.**



### 2.9 Conduct in hazardous situations

All safety equipment for the emergency services (first aid supplies, emergency escape routes, emergency showers, stretchers), for the machine (emergency stop button, main switch, fuse boxes, ground fault circuit interrupter, etc.), for fire prevention (fire extinguishers, smoke and heat extraction systems, pushbutton alarms, triggers for other extinguishing systems) and the usual traffic routes must be kept clear at all times.

### 2.10 Additional notices



#### ACHTUNG

The provisions set out in the accident prevention regulations laid down by the employer's liability insurance association apply to all work on the machine.

In addition, the following must be observed:

- Applicable binding accident protection regulations
- Applicable binding regulations at the place of use
- Recognised technical regulations for safe and professional working
- Existing environmental protection regulations
- Other relevant regulations

**Information signs attached to the machine must be kept in a legible condition and must not be removed!**

## 3.1 Safety notices



**WARNING**

- Installation work may only be carried out by assigned and instructed individuals.
- Only use tools that are in perfect working order to perform work. In particular, spanners must fit correctly and must not be widened. Risk of slipping!
- Test run: Check whether there are any hand tools, screws, auxiliary materials or objects in the fan's and the machine's operating range.
- Wear appropriate protective clothing when working.
- Check the supplied parts to ensure that they are complete and are free from damage or other abnormalities.

**WARNING**

- **Observe the applicable safety and accident regulations during transport. Wear the required protective equipment.**



---

### 3.2 Installation site

The nature, properties and ambient temperature of the installation site and the ambient medium used there must be appropriate for the particular fan.

## 3.3 Installation and mounting



Assembly must only be performed by specialists. They must apply these Operating and Assembly Instructions and comply with the applicable regulations.

As soon as assembly is complete (and before the fan is connected to the mains power supply), refit protective fixtures removed for the assembly work.

When attaching, avoid redundancy caused by using several points of attachment. Ensure that an appropriate motor protection switch is fitted.

Assemble and install the fan in such a way that it cannot tilt, fall over or fall down. Comply with this requirement when operating, maintaining, cleaning, servicing, etc., the fan and any of its individual components. Suitable personal protective equipment must be specified and worn at all times. Heavy devices pose particular crushing or shearing hazards. Secure these devices properly before starting work on them.

The fan must not be subjected to impermissibly high vibration or shock loads. Open intake or blow-out connections must be covered with protective grilles in accordance with the currently applicable standard. Ensure that the motor is properly ventilated. Minimum distance between wall and cooling fan cover: 20 mm.



**ACHTUNG**

**THE RADIAL FAN MAY ONLY BE ASSEMBLED BY AN INSTRUCTED SPECIALIST!**

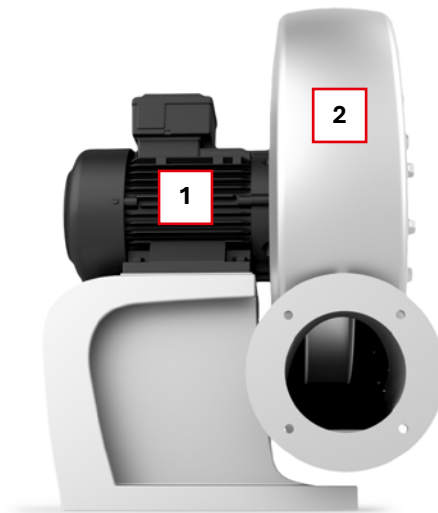

**Image: 3.1 Radial fan**

**Nr. Component name**

**1 Drive**

**2 Fan housing with impeller**

### 3.4 Disassembly and transport



**WARNING**

**Transport may only be carried out by a specially instructed specialist!**

**Please immediately check that the delivery is complete and intact, in the presence of the delivery firm.**

**Do not store the fan outdoors without suitable protection. Protect from moisture.**

**Attach lifting tackle securely. Only use lifting tackle and accessories with a sufficient load-bearing capacity.**



If motors or units are fitted with shock sensors, check their status before installation. If the shock sensors have been triggered, the Dietz-motoren product/unit must be returned to the manufacturer for inspection.

### 4.1 Safety notices

- Observe the safety notices set out in Section 2 of these Operating and Assembly Instructions.
- If applicable, when working with the radial fan, the documentation for the entire machine must be observed in addition to these Operating and Assembly Instructions.

## 4.2 Operating instructions

**Important:**

**The radial fan is designed for installation in a machine.**

**It is prohibited to operate this radial fan until it has been ensured that all the health and safety requirements as set out in the EC Machinery Directive have been met.**

**Note the following points when assembling and commissioning the fan:**

- Carefully check that the device is in proper condition before commissioning it or running it again later.
  - For example, devices that are damaged upon delivery or installation must not be operated.
  - Ensure that the motor is adequately protected against the ingress of foreign objects and iron oxides.
  - Only regularly trained specialists are permitted to fit, operate and maintain the devices.
  - Operation following incorrect assembly or maintenance will result in unintended use.
  - Carry out electrical installation in accordance with the currently valid safety standard for machines. Ensure complete potential equalisation: i.e. sufficient, proper, professional earthing of all electrically conductive parts. An earth conductor must always be connected to the earth conductor terminal in the terminal box. If necessary, there is an additional earth conductor terminal on the motor/fan housing. This must then also be connected.
- 
- Ensure access for regular device cleaning and maintenance.
  - Before you switch on a fan, ensure that no foreign bodies are present in the area in contact with the medium.

Fans must not be operated if vibration levels exceed the permitted levels. Comply with the regulations indicated in the currently valid version of ISO 14694. Vibrations can indicate, among other things, that the fan impeller is dangerously unbalanced. Vibration levels must be checked every time an abnormality is detected, before first use, before use again at a later time, and every time maintenance is performed on the front and rear bearing seat on the drive motor. Do not continue operating the fan if vibration limit values are exceeded. Take immediate appropriate action to resolve the cause of the vibrations. Contact Dietz-motoren for advice.

Vibration limit values:

Limit values indicated in ISO 14694	Starre Befestigung mm/s	Flexible attachment mm/s
Initial value	4,5	6,3
Alarm limit	7,1	11,8
Shutdown value	9,0	12,5

These values apply to fans in industrial use.

### 4.3 Connection to the mains power supply



**The electrical connection must be carried out by a properly trained specialist, and in accordance with the accompanying circuit diagram and the accompanying Safety Information.**

Comply with the general installation notices when connecting the device to the mains power supply. The earth conductor terminal is located on the terminal box.

Connect the motor in accordance with the enclosed connection diagram.

For motors that are fitted with a frequency inverter, comply with the Operating Instructions provided by the frequency inverter manufacturer.

### 4.4 Checking the direction of rotation

Switch on the fan. Depending on what is required for the particular model, the motor must be connected so that it rotates in a clockwise or anticlockwise direction. If it rotates in the wrong direction, swap the L1 and L3 connections. Do not operate the fan in the wrong direction of rotation.

### 4.5 Decommissioning the radial fan

If you intend to take the radial fan out of service for longer than 1 month, you must carry out the following storage measures:

- Passivate parts that are prone to corrosion.
- Cover the radial fan to protect it against dirt.

### 4.6 Disposal

Continued use of defective fans or their components, such as impellers, roller bearings, etc., might cause physical damage to them, injury or harm to the environment. All of the fan's components must be disposed of professionally in accordance with national and international legislation and regulations.



### 5.1 Safety notices

Comply with the manufacturer's maintenance specifications and the data provided for the switching and control devices. Repairs must only be carried out by the manufacturer.

Any changes to operating conditions must be agreed with Dietz-motoren.

Comply with all applicable regulations and manufacturer's notes when performing maintenance tasks.

If the fan transports dirty air or air that contains particles, the impeller must be cleaned at appropriate intervals to prevent the dirt from caking

The fan must be checked regularly (at least every six months) for mechanical vibrations. The maximum vibration velocity in a radial direction on the bearings and/or on the motor's end shield is 4.5 mm/s. A dirty impeller might result in imbalance and damage.

If wear or dirt on the housing, impeller or other moving parts (corrosion, abrasion, material caking) is to be expected, because of the nature of the medium flowing through the fan inspect the fan regularly and clean it if necessary. The intervals are based on the local operating conditions and must be set by the operator. Do not use high-pressure cleaners or steam jets to clean the fan!

### 5.2 Spare parts

Defective parts must be replaced. To identify the spare part you are looking for, please contact Dietz-motoren.



**When replacing parts, ensure that only genuine parts are used.**

## 5.3 Notices

### 5.3.1 Cleaning, servicing and repairs

- Measure: Lock the drive electrically to prevent it from being switched back on. Warning: Impeller might keep turning for some time!
- For safety reasons, only specially trained service specialists from Dietz-motoren or a company authorised by Dietz-motoren are permitted to replace components and repair Dietz-motoren fans. If anyone else performs this work, this will result in loss of the warranty and Dietz-motoren will no longer accept any liability.
- To retain full functionality and the agreed warranty, only use genuine manufacturer's spare parts.
- A dirty impeller with dust deposits, for example, might cause imbalance and damage.
- To prevent such risks, comply with inspection and cleaning intervals that are appropriate for the fan's use.
- Cleaning must not damage the fan or impact its safety or ability to work properly. Stop using the product if there is any reason to believe that the fan has been damaged or has become unsafe or unable to work properly. Ask the manufacturer for advice. We then recommend that the fan be inspected at Dietz-motoren.
- Any intervals shortened by the operator as required by the operating conditions must be observed.
- The impeller's balance must not deteriorate due to cleaning.
- Visual inspection, in particular of moving fan parts such as the impeller, fan housing and suction cover for possible damage, traces of wear, abrasion, cracks, fractures, deformation, verification that the earthing is working properly, inspection of the radial shaft sealing rings, etc.
- Check the condition of the bearings, radial shaft sealing rings and other components that are liable to wear at least every time maintenance is performed. They must be in perfect condition.
- Bearing life: Precision bearings designed for a nominal life (L10h in accordance with the current standard) of 30,000 operating hours are used. The bearings must be replaced at the end of the grease service life (under standard ambient conditions, 30,000 h).

#### **Warning!**

Only use bearings that have been approved by the manufacturer.



**WARNING**

Notice!

The stated operating hours apply at nominal speed and with intended use, but not, for example, if frequent switching occurs or if the fan is operated at high temperatures. Depending on the ambient conditions, bearings and radial shaft sealing rings might have to be replaced sooner.

You must always check whether potential equalisation is properly installed during maintenance, and correct it if necessary.

The information about operating hours does not apply to high-pressure radial fans in the HR series or to fans that have particular operating conditions and may therefore have different and, in some cases, higher permitted operating speeds. In these cases, the maintenance intervals must be shortened significantly to prevent damage to the bearings, because the grease service life is much shorter.

## 5.3 Notices

### **General notices that must be observed:**

- Only carry out cleaning work with suitable agents.
- After cleaning, remove all tools and check the function of the cleaned area.



**Only clean components when they are cold.**

### **5.3.2 Fastening elements**

Before commissioning, check all the fastening elements to ensure that they are tight.